



**TECHNICAL
SAFETY BC**

Safe technical systems. Everywhere.

INVESTIGATION REPORT

FAILURE OF GAS FURNACES
WITH POLYPROPYLENE LINED
CONDENSING HEAT EXCHANGERS



Safe technical systems. Everywhere.

Technical Safety BC is an independent, self-funded organization that oversees the safe installation and operation of technical systems and equipment. In addition to issuing permits, licences and certificates, we work with industry to reduce safety risks through assessment, education and outreach, enforcement, and research.



Table of Contents

EXECUTIVE SUMMARY	2
CONCLUSIONS	3
1.0 PRODUCT DESCRIPTION	5
1.1 Service Instructions and Bulletins	
2.0 INVESTIGATION	7
2.1 Laboratory Testing	
2.2 Engineering Analysis	
2.3 Gas Contractors	
2.4 Manufacturer	
2.5 Owners	
2.6 Safety Barriers	
3.0 SUMMARY	14
4.0 RECOMMENDATIONS	15
5.0 APPENDICES	16
A: Scope of Investigation	
B: Furnace Certification Standard and Models Affected	
C: Incidents Investigated	
D: Manufacture’s Literature	
E: Contractor Comments	
F: Effects of Carbon Monoxide	
G: Safety Barriers	
H: Technical Safety BC Jurisdiction and Role	
I: 90% Multi-Poise Condensing Furnaces Heat Exchanger and Sooting	
J: Technical Safety BC Incident Investigation #1	
K: Technical Safety BC Incident Investigation #2	
L: Technical Safety BC Incident Investigation #3	
M: Technical Safety BC Incident Investigation #4	
N: Technical Safety BC Investigation Incident #5	
O: Acuren Report - Tube Failure Evaluations, Furnace Secondary Heat Exchangers	
P: Associated Engineering - Furnace Failure Investigations	

Executive Summary

Technical Safety BC received multiple notifications of carbon monoxide exposures that involved failures in a common product line of residential gas burning furnaces manufactured between 1989 and 2011. Although the manufacturer ceased production of these furnaces in 2011, a large number of existing furnaces remain in operation throughout the province. Exposure to carbon monoxide (CO) can be hazardous to health and quickly life threatening if not detected. Technical Safety BC decided to investigate these incidents together to ensure that common factors were identified and thoroughly examined as part of the investigation process.

Technical Safety BC's investigation has found that each of the incidents resulted from furnaces that had a common design feature that contributed to the failures, specifically, polypropylene lined secondary heat exchangers. This component was found to be susceptible to corrosion, which interfered with combustion air flow, producing CO. CO was found in occupied living spaces, having escaped the furnaces due to corrosion holes in the heat exchangers or due to corrosion blockage that allowed CO gases to circulate back into the home in certain venting configurations. It was further determined that built-in automatic safety devices did not reliably detect the conditions produced by the corroded secondary heat exchangers.

Service and maintenance instructions provided with the furnace did not include processes to support owners or contractors in detecting a corroding secondary heat exchanger in advance of failure. Subsequent service bulletins distributed through authorized dealers included procedures to properly diagnose furnace failures that produced elevated CO levels. Efforts to communicate this important procedure with other contractors or homeowners were not evident.

Technical Safety BC found that the manufacturer's repair instructions called for replacement of a failed heat exchanger with a new part of the same design and materials. Failures investigated occurred within 20 - 60% of the service life of the furnace heat exchangers and therefore repaired units remain susceptible to repeated failures. The manufacturer stopped producing these furnaces in 2011 but existing furnaces continue to operate, and some failures were reported to Technical Safety BC.

These furnaces have the potential to release elevated levels of CO for some time before being identified, and occupants may not be made aware of the potential hazard in their homes.

Exposure to CO can be hazardous or fatal to humans and animals. Health effects of CO exposures are identified in acute exposure guidelines published by the National Research Council, Appendix F. Disabling effects can occur with 8-hour exposures to concentrations as low as 27 ppm (parts per million), death can occur with 8-hour exposures as low as 130 ppm and in as little as 10 minutes with concentrations of 1700 ppm. Long term exposure to lower levels of CO can also lead to adverse health outcomes.

Conclusions

The investigations conducted by Technical Safety BC concluded the following regarding the cause of furnace failures and hazards associated with these failures.

Furnace design deficiency

A common design feature of the failed furnaces was a polypropylene-lined heat exchanger. The design feature was patented by Carrier Corporation and used in approximately 40 different models of furnaces manufactured by Carrier Corporation. In each of the failures investigated, this design of heat exchanger had failed before the end of its service life of 20 years.

Furnaces failed prematurely

Carrier offers a 20-year warranty on the heat exchangers of the furnaces. Technical Safety BC investigations of five furnaces found that they had failed within 5 to 13 years, 10 years on average. These failures resulted in the furnaces producing elevated levels of CO in the flue gas, which was found to have entered the homes.

Furnace safety devices did not perform reliably

A corroded heat exchanger reduces airflow to the burner flame causing it to produce high levels of CO. In this condition the flame can “roll out” from the burners into the burner box. The furnaces have a built-in flame rollout safety switch designed to detect this problem and shut the furnace down. In three of the incidents investigated this safety device did not perform this function, and furnaces continued to run while producing elevated levels of CO.

Another safety device built into the furnace is a pressure switch, which should turn the furnace off if the fan stops working, or if there are blockages in the air inlet or venting system (outside the furnace). However, in the furnaces investigated, the corrosion failure resulted in pressure increase that this safety device did not detect.

Warranty replacement parts also fail

Carrier Corporation’s furnace warranty provides a replacement heat exchanger, in the event of failure. These replacement heat exchangers were found to have the same design and material deficiency as the original components, subject to the same potential for failure as the original part. In one case investigated, a new replacement heat exchanger failed within five years of the repair. Contractors in the province have reported replacing these heat exchangers multiple times in the same furnaces. One contractor stated they had, in one instance, replaced this component three times in the same furnace.

Furnace service & maintenance instructions

Manufacturer's service and maintenance instructions are used by owners and service contractors to maintain furnaces in good working order. The manufacturer's instructions for the furnaces investigated state that the secondary heat exchanger, "CANNOT be serviced or inspected". The secondary heat exchanger in the furnace is not serviceable or accessible for inspection, given this, the component should remain functional throughout the entire 20-year service life. However, the furnace heat exchangers were found to have failed within 13 years and resulted in CO entering living spaces in some cases.

Service contractors can fail to diagnose the problem

The secondary heat exchanger is not accessible for inspection so service contractors may not detect a degraded secondary heat exchanger. CO testing is not included in the manufacturer's service instructions as a requirement for annual furnace maintenance. Service contractors interviewed stated that it is not a standard practice to measure CO in flue gas as part of annual servicing. However, routine combustion testing by contractors could detect when a furnace is producing high levels of CO, and action could be taken to prevent harmful exposure to CO.

Dealer Service bulletins were issued in 2007 and 2009 that provided new instructions for service contractors to conduct testing of flue gases to identify when secondary heat exchangers have failed and are producing high levels of CO. This same testing, if conducted on an annual basis could have been used to prevent the failure, however, this routine testing was not stipulated in the furnace manufacturers service bulletins. Therefore, these furnaces could be releasing elevated levels of CO for some time before being identified and occupants may not be made aware of the potential hazard in their homes.

In order to mitigate an elevated risk of CO exposure that these remaining furnaces in service present to home occupants, Technical Safety BC has issued three recommendations to improve hazard disclosure and detection, as summarized in section 4.0 Recommendations.

1.0 Product Description

The products investigated in this report are brands of gas furnaces manufactured by Carrier Corporation, including Carrier, Payne, Day & Night, and Bryant. All of the models investigated were high efficiency gas furnaces. High efficiency furnaces have both a primary heat exchanger and a secondary condensing heat exchanger that provides heating air efficiency above 90%. Once efficiency rises above 90%, moisture in the flue gas condenses and collects in the secondary heat exchanger and should be drained out of the furnace. The condensate has acidic properties which are corrosive to many metals. Many condensing heat exchangers in gas furnaces are manufactured of stainless steel which is resistant to corrosion. Rather than stainless steel, some brands of Carrier furnaces used a mild steel with a polypropylene liner, which was intended to provide corrosion resistance.

The furnace produces flue gas from the burners which is drawn through the primary and secondary heat exchangers by a draft inducer fan, Figure 1. The flue gas passes through the primary heat exchanger, enters a coupling box, then is drawn through the tubes of the secondary heat exchanger before being forced outdoors through a venting system, Figure 2. The cooler home heating air is drawn through the return air duct and is pushed by the blower through the heating unit and into the home as warmer air. The oxygen source (combustion air) may be piped directly from outdoors or drawn in from the space where the heating unit is located.

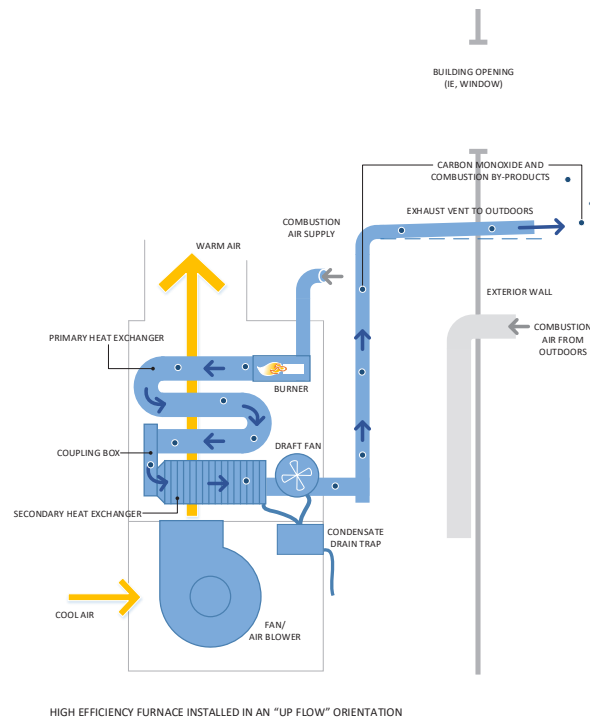
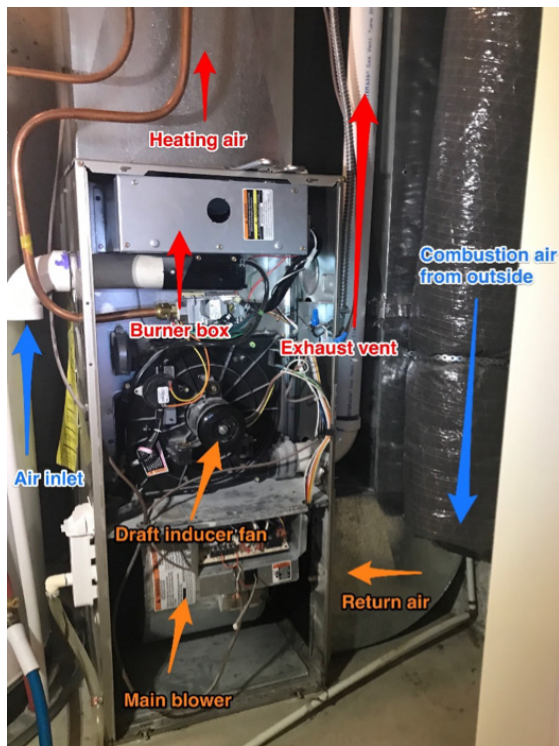

Figure 1: (Left) Gas furnace front cover removed to show main compents that are visible, secondary heat exchanger not visible as the furnace must be disassembled to access; (Right) Diagram of flue gas flow inside the furnace components.

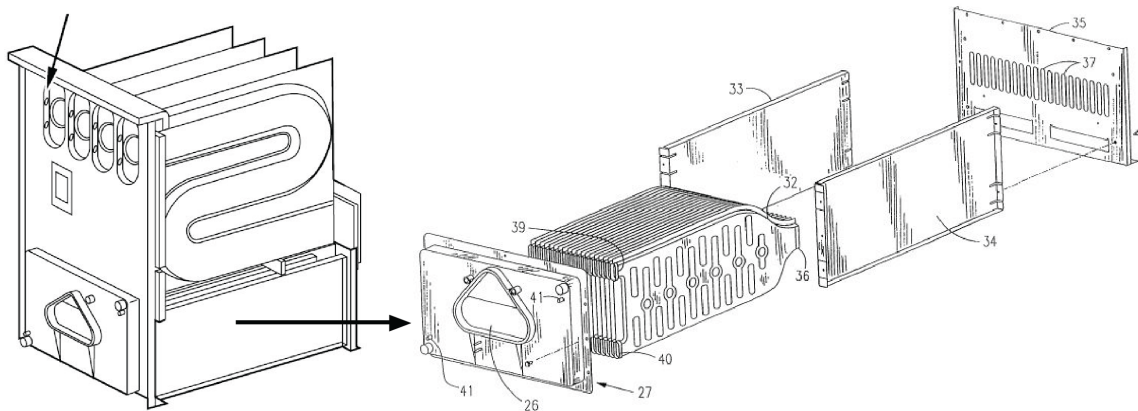

Figure 2: Expanded diagram showing secondary heat exchanger, located below the primary heat exchanger (Carrier Service and Maintenance manual, and Carrier patent document).

The furnaces were certified to the ANSI Z 21.47/CSA 2.3 design standard for gas-fired central furnaces. This standard requires the secondary heat exchanger surfaces in contact with flue gas to be corrosion resistant to flue gas condensate. The standard also requires that furnaces have safety devices, including a flame rollout switch and pressure switch (or equivalent). Further information on the certification standard is provided in Appendix B.

1.1 Service Instructions and Bulletins

The furnace Service and Maintenance Instructions detail how to maintain the furnace in good working order. These instructions state that the heat exchangers are not serviceable or accessible for inspection while in the furnace. It is not possible through typical furnace inspection procedures to identify corrosion in the heat exchanger that may cause a furnace to start producing elevated CO levels.

Carrier Corporation began manufacturing these furnace models in 1989. Following a series of failures, the manufacturer issued a Dealer Service Bulletin in 2007 and again in 2009, to identify failure of secondary heat exchangers for the purpose of warranty acceptance. The bulletin provides instructions to service contractors, for conducting testing to identify when the secondary heat exchanger has failed. The bulletin did not contain information on prevention or early detection of potential failure. The first step in the instructions is to test for the presence of CO in the flue gas by combustion analysis. If the flue gas measures less than 200 ppm of CO, no further inspection is required, and the secondary heat exchanger is not considered “failing” although corrosion may be present. This eliminates the opportunity to identify a degraded heat exchanger in the early stages of failure. To determine if the furnace secondary heat exchanger is corroding, before elevated levels of CO are produced, it must be removed from the furnace to visually inspect the inlets. A one-time inspection may not be enough to identify a progressing problem, rather, combustion testing would need to be

Carrier sent the Dealer Service Bulletin to those contractors who were Carrier dealers, informing of the new testing required to identify failed furnaces. Non-dealer contractors may not have received the instructions on how to identify failed furnaces. It is possible that service contractors who provide combustion analysis services during routine inspections could have detected the problem. There is no standard industry requirement for combustion analysis to be conducted on furnaces during routine servicing.

2.0 Investigation

The incidents involved four brand names of Carrier Corporation furnaces that have a common design feature, a secondary heat exchanger with a patented (Serpentuff™) polypropylene laminated steel liner. Refer to Appendix B for the full lists of relevant furnace brands and models.

Five furnaces were investigated that had experienced failures, representing three Carrier models of the 58MCB and 58MVB series. The furnaces installations were inspected and tested to measure CO produced by the furnaces. Technical Safety BC examined the furnaces and conducted a detailed investigation of these incidents including laboratory analysis and engineering assessment. In the incidents investigated, the furnaces were found to be producing elevated CO in the flue gas. In three of these cases CO from the furnace was measured inside the homes, resulting in CO exposure to occupants. In one case, three people were transported to a hospital for treatment due to CO exposure. A summary of findings and conclusions from these incident investigations are provided in Table 1 below, (also refer to Appendix C). Incident Summary Reports for each investigation are available in Appendices J to N.

YEARS OF OPERATION	SHUT OFF BY SAFETY DEVICE	CO IN FLUE	CO IN HOME	INVESTIGATION RESULTS (REFER TO APPENDICES J-N)
5	No	775 ppm		New replacement heat exchanger failed after 5 years and produced high levels of CO. Failure due to design and materials of the heat exchanger.
10	Yes	1000 ppm		Design and materials of the heat exchanger caused failure that created high levels of CO to be produced.
10	Yes - bypassed		8 ppm	Design of the heat exchanger caused the failure and allowed CO to enter home. Bypassed safety switch allowed continued operation of the furnace while producing CO.
12	No		23 ppm	Failure due to corrosion of the secondary heat exchanger, caused furnace to produced CO in the heating air supplied into the home.
13	No		176 ppm	Design of the heat exchanger caused failure due to corrosion blockage and perforations, which cause the furnace to produce high levels of CO that entered the home.

Table 1: Summary of incident findings and incident cause.

The first incident listed in Table 1 involved a secondary heat exchanger that had failed in five years. This unit had replaced the original unit that had failed after 10 years of operation and was replaced under warranty. The replacement unit had also failed and produced elevated levels of CO, but within only in 5 years of operation. The installation setup and routine maintenance of this unit was found to have been conducted correctly as per manufacturers requirements and was fully documented.

2.1 Laboratory Testing

Furnace heat exchanger components were sent to an independent laboratory for testing and analysis. Detailed analysis was conducted, which identified the cause of the failures. The report concluded that the furnaces failed due to rapid corrosion of the heat exchangers. The rapid corrosion was influenced by the furnace design, specifically the polypropylene lined secondary heat exchanger. It was determined that the liner delaminating from the underlying steel at the inlet to the tubes exposed it to the acidic properties of the condensate.

Ongoing condensate evaporation and condensation cycles can increase the concentration of sulfuric acid in the heat exchanger. Laboratory test results are summarized below, (refer to Appendix O):

1. Corrosion in the furnace secondary heat exchanger can begin prior to five years of service.
2. Warranty replacement secondary heat exchangers were the same design and materials as the original components and would likely fail at the same accelerated rate.
3. Corrosion produced holes in the secondary heat exchanger.
4. Liner deterioration, delamination and corrosion caused partial blockage to air flow which may result in a positive pressure that could allow flue gas containing high levels of CO to escape the furnace.
5. Similar corrosion and blockages could be expected on all furnaces of similar design related to time in service.

2.2 Engineering Analysis

Engineering analysis was conducted to determine the effect of corrosion blockages in these furnaces and the mechanism of CO production, such that elevated levels of CO were present inside homes. The engineering assessment confirmed that the degraded liner and corrosion caused a restriction in the flow of the flue gas, resulting in less air being drawn in for combustion. This produced incomplete combustion and elevated levels of CO in the flue gas. The secondary heat exchangers were found to have been partially or completely severed due to advanced corrosion, allowing flue gas and CO to be distributed throughout the home (Appendix P).

The engineering assessment confirmed how corrosion would both lead to the production of CO and its transmission throughout the home. The engineering report identifies that corrosion leads to CO production as follows:

1. The restrictions cause reduced excess (combustion) air and thus improper air-to-fuel ratios.
2. Improper fuel air mixture ratios cause increased CO production in the flue gas.

The engineering report identifies that as corrosion progresses, increased CO in the flue gas can be transmitted into the home through:

- a) holes between the secondary heat exchanger and the furnace return/supply air duct to the home.
- b) combustion air opening in the burner box.

The Technical Safety BC investigations found that the furnaces failed due to the flue gas condensate corroding the secondary heat exchanger. In 3 of 5 of the incidents, the flame rollout safety device did not shut down the furnace and continued to produce high levels of CO in a failed condition.

In a properly functioning gas furnace the products of combustion, including CO, are exhausted safely outdoors through the flue gas vent, as shown on the left of Figure 3. The engineering assessment found that in failed furnaces CO could enter the home via burner box opening and through openings at the secondary heat exchanger, caused by severe corrosion, as illustrated on the right of Figure 3.

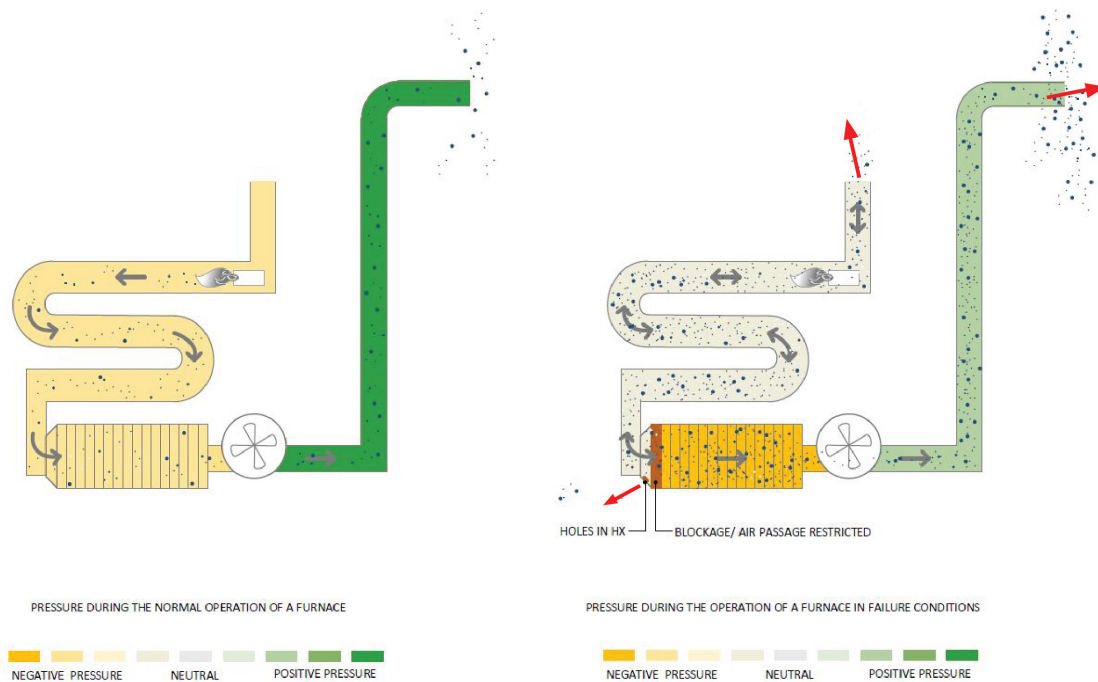

Figure 3: Internal pressures, gas flow and CO produced in normal (left) and failed (right) condition (red arrows show paths for CO escaping furnace).

2.3 Gas Contractors

Furnace installation and maintenance companies throughout the province were interviewed regarding these incidents. These interviews gauged awareness, scope of the problem and risks associated with the furnace failures. Each of the contractors interviewed had responded to a number of similar secondary heat exchanger failures, and had measured CO being produced by these furnaces, some in excess of 9000 ppm.

Gas contractors do not always measure the CO levels produced by furnaces as part of routine maintenance, and it is not required in the manufacturer's service manual. Routine service inspections would not likely identify a furnace at risk of producing elevated CO due to a corroded secondary heat exchanger. Service contractors would need to be aware of the potential failure mechanism and use specialized equipment to conduct combustion analysis of flue gases to determine if a secondary heat exchanger had failed. Combustion analyzer devices are not part of the standard equipment carried by all service contractors, rather, the testing is done only in special circumstances. Further, if this analysis identified problems, contractors would need to dismantle a significant portion of the furnace and remove the secondary heat exchanger to visually verify the cause of failure.

In 2007, Carrier Corporation introduced three new documents, a Dealer Service Bulletin, and a Heat exchanger inspection procedure, and Heat exchanger sooting guide. They were issued to registered dealer contractors directly and indirectly through the dealer network locations.

Non-dealer contractors did not receive the information directly from the manufacturer, although it may have been available through contacting the manufacturer directly or independent research.

Refer to Appendix E for further details.

2.4 Manufacturer

Since the start of production in 1989, numerous failures of the same style of furnace occurred due to failing secondary heat exchangers. The furnace manufacturer offers a 20-year warranty on the secondary heat exchangers and the manufacturer provided contractors who were Carrier dealers with instructions for inspecting and testing the furnace for warranty purposes. The manufacture required a form ("90% Furnace Secondary Heat Exchanger Inspection Certificate") to be submitted by contractors for enhanced warranty claims of secondary heat exchangers of the affected furnaces.

Technical Safety BC acquired completed inspection certificate forms from the manufacturer, Carrier Corporation. Examination of these warranty forms found that CO levels in the flue gas of the operational furnaces were recorded in the range of 306 to 1799 parts per million (ppm). The manufacturer responded to successful warranty claims by providing a replacement secondary heat exchanger of the same design and materials which were subject to the same failure process as the original units. All owners may not have submitted such a warranty claim,

for example, investigation of five incidents found that only one had received a new secondary heat exchanger on warranty (which subsequently failed). A more effective action for Carrier Corporation would be to provide broader public communication of these furnace issues.

The Carrier Corporation furnace brands affected include Carrier, Payne, Day & Night, and Bryant. Bryant and Carrier published a document that provides details of the furnace sulfuric acid corrosion process in furnaces with polypropylene-lined secondary heat exchangers. This document also provided instructions for proper setup and maintenance.

Refer to further details in Appendix D.

Manufacturer's failure description

Carrier published documents that explain how and why the furnaces heat exchangers fail, titled 90% Multi-Poise Condensing Furnaces Heat Exchanger and Sooting, (refer to Appendix I). This document explains how sulfuric acid in the furnace flue gas can cause the secondary heat exchanger to corrode. It also states that this condition cannot be identified using visual inspection only and combustion analysis is required.

Excerpts below:

The concentration of sulfuric acid in the area of the primary cell outlet, cold spot baffle, coupling box, and secondary heat exchanger inlet can cause them to corrode. This sulfuric acid attacks unprotected areas of the secondary heat exchanger and can cause the polypropylene to separate from the base metal.

When the corrosion from these components begins to block the heat exchanger passages, the amount of air available for proper combustion is reduced. The condensing furnaces are designed to operate with excess air greater than 60%. When the excess air is reduced to below 30%, sooting can start. The corrosion and soot block additional heat exchanger passages until the furnace fails to operate properly. The pressure switch will not prevent the furnace from operating since this heat exchanger blockage will cause the pressure differential across the heat exchanger to increase. Visual inspection of the burners will not indicate reduced excess air until they begin to develop yellow tipping or sooting. Combustion analysis is necessary to determine excess air levels.

Carrier states that corrosion in the secondary heat exchanger can reduce the amount of air available for combustions, such that excess air is reduced below 60%. Another effect of reduced air supply is that increased CO can be produced. This effect of producing CO is not mentioned in the Carrier document. Furnaces with corroded heat exchangers have been found to produce high levels of CO. This CO has been found to enter homes, as found in some incidents investigated. Carrier also states that combustion analysis is required to detect this problem. However, combustion analysis is not a specified as part of the annual service maintenance required for these furnaces (Reference: Carrier furnace installation, start-up and operating instructions, and Carrier service and maintenance instructions).

Carrier stated that the two most common causes of furnace sooting are improper setup and maintenance, and high sulfur levels in the fuel. However, as explained in the Carrier document, sulfur that is contained in gas will condense, accumulate, and concentrate in the secondary heat exchanger. Therefore, the sulfur concentration can cause “sulfuric acid” corrosion over repeated heating and condensation cycles normally experienced by gas fueled furnaces.

Refer to Appendix I for the full document.

2.4.1 Manufacturer Comments

Technical Safety BC provided its investigation findings to the furnace manufacturer, Carrier Corporation (“Carrier”). Carrier provided a copy of a report that details experiments conducted to simulate corrosion perforations in a secondary heat exchanger. Carrier concluded that CO cannot be released into the home through the furnaces.

Technical Safety BC investigated incidents where carbon monoxide was measured within the home. Other possible sources were ruled out and limited to the furnace. The furnaces and venting systems were found to be installed per the relevant codes and manufacturer’s instructions. The furnaces were maintained following manufacturer’s instructions, except in one case where a safety switch was by-passed. Carbon monoxide was measured to be entering the homes from the air circulation system in two incidents and from the furnace room in another.

Technical Safety BC appreciates the testing and conclusions of the manufacturer however measured a different outcome in the field that involved severely corroded heat exchangers. Testing results from five investigations lead us to the conclusion that, despite the information received from Carrier, the units we observed were in fact producing CO as a result of blockages and perforations caused by the SHX corrosion. As such Technical Safety BC maintains its conclusions, as stated in this report.

2.5 Owners

The owner or operator of a gas furnace may choose to contact a service contractor to ensure routine testing, service and maintenance is completed, as prescribed in the furnace service and maintenance instructions.

Owners and operators of furnaces that contained the subject secondary heat exchangers may not have been directly informed by the manufacturer of the Dealer Service Bulletin and potential issues with CO being produced by these furnaces. It would be prudent for Carrier to ensure and verify that all service contractors (Carrier dealers) who had installed and/or maintained these furnaces contact the customers to inform them of the potential hazard.

Owners who submit product warranty registration forms may include contact information for Carrier to contact them directly to provide new product service requirements or warranty response. However, Carrier may not be aware of owners who do not provide warranty registration or otherwise provide contact information to the manufacturer. As noted in section

2.4, owners could have benefited from a broader public communication of the furnace hazards from the manufacturer.

2.6 Safety Barriers

Safety barriers are controls intended to add layers of protection to mitigate the creation of and exposure to hazards. There are preventive barriers which prevent potential sources from creating a hazard and responsive barriers which can prevent a hazard from causing a negative consequence. Preventive barriers include correct installation and maintenance and robust product design. Responsive barriers include furnace safety devices, effective venting of flue gases and CO detectors. In the incidents investigated, despite all the preventative safety barriers provided failures still occurred, and the furnace produced high levels of CO.

As the secondary heat exchangers in the furnaces begin to fail and produce elevated CO in the flue gas, the furnace may continue to operate until the problem is identified either through routine maintenance, operating problems, or an automated safety device shuts the furnace down. Investigations found that responsive barriers including furnace safety devices were not effective at preventing elevated CO production and exposure. Refer to Appendix G for a detailed discussion of the preventive and responsive barriers.

3.0 Summary

Major findings by the investigation conducted by Technical Safety BC are summarized below. Refer to Appendices for further details.

- a. Degradation of the polypropylene lined secondary heat exchanger can lead to incomplete combustion which can produce elevated levels of CO. The failure mechanism is explained by Carrier (Appendix I) and by an independent laboratory (Appendix O), and through engineering assessment (Appendix P). This failure mechanism appears limited to the brands of furnaces with a polypropylene lined steel secondary heat exchanger. The brands include 20 models of Carrier furnaces and 24 models of Payne, Bryant, and Day & Night furnaces. (Appendix B).
- b. CO was detected inside homes of three furnaces investigated. Engineering analysis indicated that CO may enter a home through corrosion holes in the furnace secondary heat exchanger, or spill back through the furnace combustion air opening in some furnace configurations.
- c. Carrier offers a 20-year warranty on the furnace secondary heat exchangers. However, the failures investigated all occurred inside the warranty period and ranged from 5 to 13 years, (average 10 years) in the furnaces investigated.
- d. Warranty replacement secondary heat exchangers are the same design and materials as the originals and can fail at the same rate as the original units. Furnaces can continue the cycle of degradation and thereby increasing the time of potential exposure to CO.
- e. Safety barriers were ineffective at mitigating the hazard in the instances investigated.

4.0 Recommendations

Technical Safety BC's investigation has found that furnaces incorporating polypropylene lined heat exchangers are at an elevated risk of corrosion failure and exposing persons to CO. As a result of these investigation findings Technical Safety BC makes the following recommendations to promote the disclosure and servicing necessary to mitigate this risk of CO exposure:

1. **The Manufacturer** is recommended to provide general disclosure to owners and non-dealer contractors of the potential for elevated CO levels due to corroded secondary heat exchangers and provide instructions for prevention and early detection. These instructions should include regular combustion testing, CO detectors, and/or periodic replacement of the secondary heat exchangers.
2. **Owners** are recommended to request a licensed contractor to regularly test for the presence of elevated CO and inspect and repair affected furnaces through the remaining appliance service life.
3. **Licensed contractors** are recommended to conduct combustion analysis to detect the production of elevated CO, inspect and repair affected heat exchangers as part of regular servicing of these affected units.

5.0 Appendices

Appendix A: Scope of Investigation

The discussion and conclusions in this report are based on the evidence presented and available at the time of Technical Safety BC's investigation conducted between February 2020 and December 2020. The investigation focused on furnaces incorporating Carrier Corporation's patented polypropylene lined condensing heat exchanger (PLCHX). The investigation includes five separate incident investigations and multiple contractor notifications involving hazardous levels of CO being produced by furnaces due to degraded PLCHX's. The investigation also sought to understand:

- Cause and contributing factors of the PLCHX's deterioration
- The impact of hazards associated with the PLCHX's deterioration
- The scope of these hazards existing in the province
- The manufacturer's awareness of the issue and effectiveness of their response actions
- Awareness of the PLCHX's deterioration by industry, contractors, technicians, and equipment owners

Technical Safety BC's investigation aims to inform prevention to reduce the risk of incidents of these natures recurring in the future. The scope of the activity undertaken during the investigation include:

- Examination of manufacturer's product data, installation, and maintenance instructions
- Examination of gas central fired furnace Canadian standards
- Examination of furnace installation and service documentation
- Evaluation of the manufacturer's enhanced warranty policy and service bulletins
- Examination of documentation submitted by gas contractors of furnace's identified as having deteriorated PLCHX's
- Laboratory analysis of three separate PLCHX's in varying degrees of deterioration and flow blockage
- Operation tests of installed furnaces with a deteriorated PLCHX's
- Comparison of the PLCHX's lifecycle with other designs and materials
- Interviews of contractors, technicians, and equipment owners of the furnaces
- Interviews of the manufacturer and dealer network representatives
- Interviews of Technical Safety BC Gas Safety Officers

- Interviews of a sample group of contractors and technicians throughout the province
- Examination of class action lawsuit settlement agreement

References:

- ANSI Z 21.47/CSA 2.3 design standard for gas-fired central furnaces
- CDC NIOSH – Immediately dangerous to life and health concentrations
<https://www.cdc.gov/niosh/idlh/630080.html>
- Carrier-90multi-poise-condensing-furnace-heat-exchanger and sooting
- Heat Exchanger Inspection Report SB090024CA
- 58mcb - Installation instructions
- 58mcb-service and maintenance manual
- Carrier enhanced warranty service bulletin - Warranty Policy
- Carrier service bulletin- Heat exchanger inspection procedure
- Carrier Trade-in Allowance Dealer Handbook_19-20 (Canadian Version)
- U.S./CANADA SETTLEMENT AGREEMENT AND RELEASE
http://www.hipspro.com/pubs/Furnace-settlement_agreement-entire.pdf

Appendix B: Furnace Certification Standard and Models Affected

The furnaces manufactured by Carrier Corporation with the PLCHX's were designed, tested, constructed and 3rd party certified to the ANSI Z 21.47/CSA 2.3 design standard for gas-fired central furnaces that was current at the time. The standard requires the secondary heat exchanger surfaces in contact with flue gas to be corrosion resistant to flue gas condensate.

Product data

The following brands and models were manufactured with Carrier Corporation's patented polypropylene laminated condensing heat exchanger:

Carrier models: 58SX*, 58SXA, 58SXC, 58DX*, 58DXA, 58DXC, 58MSA, 58MCA, 58MXA, 58MCB, 58MXB, 58UVB, 58SXB*, 58VUA, 58VCA, 58MVP, 58MVB, 58MTA, 58MTB, and 58MVC

Bryant/Payne/Day & Night models: 398AAW*, 398AAZ, 398AAV, 399AAW*, 399AAZ, 399AAV, 345MAV, 340MAV, 350MAV, 340AAV, 350AAV, 351DAS, 355BAV, 398BAW*, 398BAZ, 320AAZ, 321AAZ, 355MAV, 355AAV, 352MAV, 352AAV, 490AAV, PG9MAA, and PG9MAB and 355CAV.

*The asterisk next to a model number indicates that for those models, only those with serial numbers with the last two digits of 89 or higher were manufactured using PPL CHXs.

The furnace was certified to the ANSI Z 21.47/CSA 2.3 design standard for gas-fired central furnaces that was current at the time. The standard requires the secondary heat exchanger surfaces in contact with flue gas to be corrosion resistant to flue gas condensate, and to incorporate a flame rollout safety switch. The Technical Safety BC investigations found that the furnaces examined did not resist corrosion and failed as a result. Corrosion restricted flue gas flow which can cause a flame rollout, indicative of conditions that produce elevated CO levels. Investigations also found that flame rollout safety device did not turn the furnace off in three cases and the flame was producing elevated levels of CO. Examples of clauses in the standard ANSI Z 21.47/CSA 2.3 -2006 relevant to issues noted above are provided in the excerpts below:

Materials

1.3.3

Materials intended to be in contact with fuel gases shall be resistant to the action of liquefied petroleum gases.

1.3.4

Any flue gas passageway which is directly exposed to return air on the negative pressure side of an air-circulating blower shall be constructed of a corrosion-resistant material or have a corrosion-resistant finish to resist corrosion by condensate. Steels with coatings, suitable to the conditions to which exposed, and cast iron are considered corrosion resistant.

1.3.6

Heat exchanger surfaces in contact with flue gas which have a normal operating steady state temperature not more than 150°F (65.6°C) shall be corrosion resistant to flue gas condensate. (See 2.15, Corrosion Resistance.)

2.15 Corrosion Resistance

The furnace and venting systems provided or specified shall exhibit acceptable resistance to corrosion when tested and evaluated according to procedures included in Exhibit G (Corrosion Resistance Criteria and Test Method).

G.4 Corrosion Evaluation Criteria

G.4.2, No evidence of leakage of flue gas or condensate shall be observed where condensate normally occurs in Category II and IV appliances. (This includes joints, gaskets, pipes, and condensing heat exchangers.)

1.3.7

When sheet metal is used in the construction of heating surfaces, the thickness shall be such as to provide strength, rigidity, durability, resistance to corrosion and other physical properties equivalent to 0.0304 in (0.772 mm) minimum thick AISI C1010 hot-rolled sheet steel. For minimum thickness of certain other materials, see Table I, Minimum Thickness of and Maximum Allowable Rise Above Room Temperature for Ferrous Metals.

Appendix C: Incidents Investigated

Technical Safety BC investigated five incidents involving elevated concentrations of carbon monoxide (CO) produced from furnaces with polypropylene lined condensing heat exchangers (PLCHXs). Four of the incidents took place between Jan 17th 2020 and Feb 29th 2020 and one incident took place on May 29th 2020.

Each of the specific incidents investigated provide their own set of circumstances which identify how a common failure mechanism can result in different outcomes. The results and conclusions of each incident are summarized in Table 2 below, and the full investigation reports are provided in Appendices J through N.

Common characteristics of furnaces investigated:

Carrier Corporation's patented polypropylene lined condensing heat exchangers (PLCHX) utilize flat galvanized steel tubes with a polypropylene laminated interior liner. The polypropylene liner protects the inside of the steel tube from the corrosive properties of the condensate. The PLCHX's are made up of multiple tubes connected on the ends to a common coupling box on the inlet and collector box on the outlet.

Industry began seeing failures of some of the PLCHX's shortly after installation. The failures involve delamination of the polypropylene liners and corrosion contributing to restriction of the airflow through the heat exchanger. Restrictions of the airflow lead to incomplete combustion of the fuel gas and the production of hazardous levels of CO in the furnace flue gas. Corrosion created holes in some heat exchangers that allowed the corrosive condensate and flue gas containing CO to escape.

INCIDENT NUMBER	YEARS OF OPERATION	SHUT OFF BY SAFETY	CO IN FLUE (PPM)	CO IN HOME (PPM)	INVESTIGATION CONCLUSIONS
II-928535-2020	10	Yes	1000		Furnace failure and CO production due to heat exchanger design deficiency.
II-99966-2020	10	No			Furnace failed at 10 years operation, heat exchanger replaced under warranty.
	5	No	775		New heat exchanger failed after 5 years operation due to design deficiencies, and produced high levels of CO. Furnace air intake pipe burned/melted from overheated burner box and flame rollout.
II-1020945-2020	12	No	NA	23	Design and construction materials of the PLCHX caused the incident. Corrosion caused holes which allowed CO to enter the home.
II-997950-2020	10	Yes – bypassed	NA	8 (stopped testing)	Design and construction materials of the PLCHX caused the incident. Corrosion caused holes which allowed CO to enter the home. Bypassed safety switch allowed continued operation of the furnace.
II-968311-2020	13	No	NA	176	Failure due to design of furnace heat exchanger, furnace continued operating and producing CO. Gas utility technician measured 176 ppm CO inside home with 8 occupants, sent to hospital due to CO exposure.

Table 2: Detailed summary of incidents investigations, laboratory analysis and conclusion regarding incident cause.

Photographic timeline of degradation:

These furnaces failed between 5 and 13 years of operation. All of the furnaces were found to be installed with the correct manufactures recommended slope to allow for proper drainage of the flue gas condensate. Photographs of the five furnaces investigated show the progression of degradation and corrosion over time in service. New secondary heat exchanger shows clean white polypropylene liners adhered at the inlet throats to the tubes with a black sealant around the mechanical joint between the tubes and the front plate (Image from new component from the parts supplier’s website).

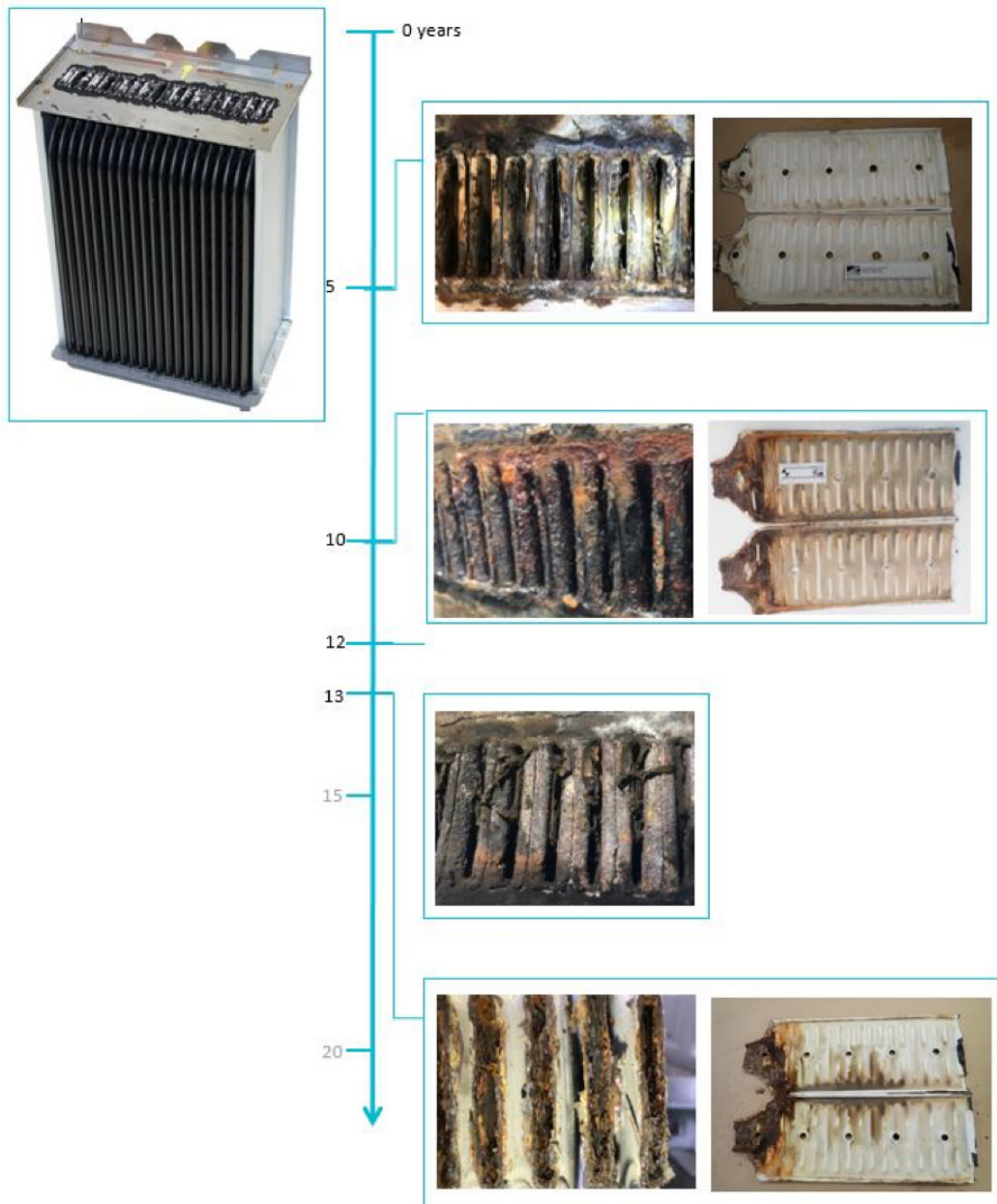

Appendix D: Manufacturer's Literature

Installation and maintenance instructions

The furnace manufacturer's installation/operating instructions delivered with every furnace provide specifications on the safe installation and operation of the furnaces. They specify that the furnaces must be sloped down towards the front to allow for proper condensate drainage from the furnace. If furnaces are incorrectly sloped during installation the condensate can collect inside the secondary heat exchanger tubes accelerating the corrosion of exposed steel.

The furnace and service/maintenance instructions delivered with every furnace provide specifications on the requirements for care and maintenance needed for safe operation of the appliance. They specify that it is essential that maintenance be performed annually on the furnaces. It lists the minimum maintenance that should be performed as:

- Clean or replace air filter each month as needed
- Check and clean blower motor and wheel
- Check electrical connections and proper operation of controls
- Check proper condensate drainage
- Check for blockages in combustion air and vent pipes
- Check burners for cleanliness

Combustion analysis is not a listed maintenance item in the service/maintenance instructions. The instructions also specify that the secondary heat exchanger cannot be serviced or inspected. Excerpts from manufacturer's service and maintenance manual (58 MCB):

Service and Maintenance Instructions (58MCB 4-Way Multipoise Fixed-Capacity Condensing Gas Furnace)

CARE AND MAINTENANCE

For continuing high performance and to minimize possible furnace failure, it is essential that maintenance be performed annually on this equipment. Consult your local dealer about proper maintenance and maintenance contract availability.

NOTE: If the heat exchangers get a heavy accumulation of soot and carbon, both the primary and secondary heat exchangers should be replaced rather than trying to clean them thoroughly due to their intricate design. A build-up of soot and carbon indicates that a problem exists which needs to be corrected, such as improper adjustment of manifold pressure, insufficient or poor quality combustion air, improper vent termination, incorrect size or damaged manifold orifice(s), improper gas, or a restricted heat exchanger (primary or secondary). Action must be taken to correct the problem.

Note that instructions state that annual maintenance is essential, however, the secondary heat exchanger cannot be maintained, only replaced.

Further, it is not possible to access the inlet to the secondary heat exchanger to inspect for soot and carbon accumulation.

The minimum maintenance that should be performed on this equipment is as follows:

1. Check and clean or replace air filter each month as needed.
2. Check blower motor and wheel for cleanliness annually.
3. Check electrical connections for tightness and controls for proper operation each heating season. Service as necessary.
4. Check for proper condensate drainage. Clean as necessary.
5. Check for blockages in combustion-air and vent pipes annually.
6. Check burners for cleanliness annually.

The list of minimum maintenance actions does not include combustion analysis, however, such analysis is required to identify if soot and carbon build-up have occurred in the secondary heat exchanger

Combustion analysis measures problem indicators including combustion air quality and CO content if flue gas.

⚠ CAUTION

UNIT MAY NOT OPERATE

Failure to follow this caution may result in intermittent unit operation or performance satisfaction.

These furnaces are equipped with a manual reset limit switch in burner box. This switch opens and shuts off power to the gas valve if an overheat condition (flame rollout) occurs in burner enclosure. Correct inadequate combustion-air supply or improper venting condition before resetting switch. **DO NOT jumper this switch.**

This limit switch failed to turn the furnace off in several incidents investigated where either or both flame rollout and inadequate combustion-air supply resulted in elevated CO production.

In one case, a jumper was found on a furnace that subsequently failed.

Secondary Heat Exchangers
 Secondary Heat exchangers shall be of a flow-through design having a patented interior laminate coating of polypropylene for greater corrosion resistance with fold-and-crimp design, which operates under negative pressure.

58 MCB product data document

SECONDARY HEAT EXCHANGERS

NOTE: The condensing side (inside) of the secondary heat exchangers CANNOT be serviced or inspected. A small number of bottom outlet openings can be inspected by removing the inducer assembly. See Flushing Collector Box and Drainage System section for details on removing inducer assembly.

**58MCB FEATURES/
 BENEFITS**

Serpentuff™—Exclusive Serpentuff coating, a patented polypropylene laminate is used on the secondary heat exchanger.

Enhance warranty bulletin

Carrier Corporation issued Service Bulletin SMB 07-0056 in 2009 with subsequent revisions detailing the enhanced warranty policy for the affected units. The service bulletin was issued through the distributor to all dealers that sell, install and service the affected furnace models. The policy coverage period is for 20 years from the original furnace installation date.

The policy covers the failures of PLCHX's and related parts. The enhanced warranty provided two options in the event of a PLCHX's failure. One option is a flat rate allowance to cover the replacement of the failed PLCHX's which includes parts and 4 hours of labour. The other option is a monetary credit allowance toward the purchase of a new Carrier, Bryant or Payne brand furnace.

Heat exchanger inspection bulletin

Carrier Corporation issued a Dealer Service Bulletin (DSB 09-0022) in 2009 for their furnace models that incorporated PLCHX's. The bulletin was issued to outline the procedure that should be utilized to properly diagnose a PLCHX failure when one has suspected to have failed. The procedure states that the PLCHX cannot be serviced or inspected without removal from the furnace and combustion analysis is required for identifying a failing PLCHX.

The bulletin states that if CO readings in the flue gas are 200ppm or less then there is no indication of a failing PLCHX and no further examination or inspection of the PLCHX is required. This says that if a PLCHX has degraded enough to be suspected of failing and requiring further testing and examination then it will be producing >200ppm at a minimum.

If CO readings in the flue gas exceed 200 ppm the procedure instructs to remove the heat exchanger from the furnace and inspect for perforation due to corrosion and inspect the heat exchanger inlets to see if the inlets are obstructed by corrosion or there is delamination of the polypropylene laminate. Those indicate a failed PLCHX that needs to be replaced

The Dealer service bulletin was distributed to registered service dealers and through the dealer parts supplier network. The Bulletin was not issued to owners of the affected equipment or non-registered service dealers.

For PLCHX failures of June 15, 2009, or later a copy of the 90% Furnace Secondary Heat Exchanger Inspection Certificate needed to be submitted as part of the warranty claim approval process.

90% Multi-Poise Condensing Furnaces Heat Exchanger and Sooting (Refer to Appendix I for full document)

In 2006 Carrier Corporation created documents (01-858-454-25 and 01-8110-414-25) titled "90% Multi-Poise Condensing Furnaces Heat Exchanger and Sooting"; the documents intent was to address operational changes of furnaces based on corrosive condensate and corrosion of the secondary heat exchanger.

When the heat exchanger passages begin to block and the excess air levels diminish, the levels of carbon monoxide in the flue gas rises. The document states that visual inspection of the burners will not indicate reduced excess air until they begin to develop yellow tipping or sooting and that during furnace setup and routine maintenance combustion analysis should be performed. The document also discusses the effect of furnace setup and maintenance.

The “90% Furnace Secondary Heat Exchanger Inspection Certificate” form is required to be submitted by contractors for all enhanced warranty claims of PLCHX’s of the affected furnaces. Completed inspection certificate forms were received from the manufacturer for investigation. The forms were examined to gain insight into the CO hazards associated with the operation of the furnaces. Review of inspection reports received from Carrier Corp. found that approximately half of the furnaces were identified as operational at the time they were examined by the contractors. Recorded CO concentrations in the flue gas of the operational furnaces ranged from 306 to 1799 parts per million (ppm).

Appendix E: Contractor Comments

Furnace installation and maintenance companies throughout the province were consulted. The sample group consisted of nine small to large companies (“contractors”) who were both registered furnace manufacture dealers and non-manufacture dealers. The purpose of the interviews was to gauge awareness, scope and risks associated with the furnace failures throughout the province. The information provided by the contractors indicates the following:

- a. All the contractors reported having found secondary heat exchanger failures of the affected models of furnaces. The affected models are those that have polypropylene lined condensing heat exchangers (“PLCHX”).
- b. The number of failures seen was in relation to the size of the company. The smallest estimated number seen in the last 10 years was 20 by one company. The most was up to 500 by a larger company with one gas fitter in the company having changed out an estimated 150 personally.
- c. It is common to find furnaces with failing PLCHX’s operating with CO levels above 1000 ppm in the flue gas. These readings in many cases were instrument limited, that is, the gas detector used could only measure a maximum of 1000 ppm CO. Examples of CO readings above 8000 ppm and 9000 ppm have been recorded using more advanced instruments.
- d. Replacing the PLCHX can result in the same failure well before the 20-year life expectancy offered by the manufacturer. The warranty replacement parts are the same design as the originals and degrade at the same rate the originals and can again start producing elevated CO without the owner being aware, until exposed.
- e. The 4 hours of labour covered by the enhanced warranty is not sufficient to replace a PLCHX. The components are supplied separately and require to be assembled by the installing contractor. Owners commonly incurred additional cost to a warranty replacement. This additional cost combined with the knowledge that failures will reoccur, contribute to many furnaces being replaced with different brands and models. When this occurs, the Manufacturer would typically not be informed of the furnace failure and would be unaware of the total number of PLCHX failures occurring.

- f. Horizontal exhaust vents (on the side of a home) can increase the hazard of exposure to elevated CO levels in flue gas entering the home through other building openings.
- g. The contractors were aware that the furnaces can operate for some time while producing elevated CO levels in the flue gas before the furnaces trip a safety device built into the furnace.
- h. Contractors stated that the life expectancy of the PLCHX's on the affected models was less than the manufacturer's warranty of 20 years, most believe the PLCHX will fail within 10 years.
- i. The solution the manufacturer provided of issuing the service bulletins and enhanced warranty did not eliminate the hazard in the incidents investigated.
- j. Installation characteristics can play a factor in how quickly a PLCHX will degrade. For example, Incorrect furnace sizing, input, natural gas to propane conversions, furnace slope and blockages in the condensate drain lines may accelerate the delamination of PLCHX's and corrosion of the underlying steel.
- k. Furnaces correctly installed following manufactures instructions and specifications have still been found to fail within 10-13 years of operation due to accelerated degradation of the PLCHX's. PLCHX's have been found to fail in as little as a year after installation and in one case the PLCHX of a furnace had failed and was replaced three times.
- l. Approximately half of the owners of the gas furnaces installed have the appliances serviced by qualified individuals and most of those owners continue to get their furnace serviced throughout the entire lifecycle of the appliance. However, the overall majority of the residential gas furnaces in use are not receiving service and maintenance at the most critical time of their lifecycle. Therefore, relying on regular service and maintenance as a barrier to stop hazardous operation due to a design flaw is not effective.

Appendix F: Effects of Carbon Monoxide

Properties of Carbon Monoxide

Colourless	Cannot be seen.
Tasteless	Cannot be detected through the sense of taste.
Odourless	Cannot be detected by sense of smell, however, CO can also be accompanied by aldehydes. Aldehydes' odour can somewhat resemble vinegar, which can be detected by the sense of smell, and may also result in a metallic taste in the mouth.
Non-irritating	Carbon monoxide will not cause irritation, however, aldehydes usually present with higher levels of CO will irritate the eyes, nose, and mucous membranes.
Specific gravity	Slightly lighter than air (Sq 0.975). It may, but not always, collect near the ceiling and mixes freely with air.
Flammable (explosive) limits	CO is flammable between concentrations of 12.5% to 74% when mixed with air. Its ignition temperature is 609°C (1128°F)
Toxic	Can cause death if enough is absorbed into the bloodstream.

Table 3 – Properties of carbon monoxide from Technical Safety BC's [Carbon Monoxide Handbook](#)

CLASSIFICATION (DESCRIPTION)	DURATION				
	10 MIN	30 MIN	1 HOUR	4 HOURS	8 HOURS
Disabling Irreversible or other serious, long-lasting adverse health effects, or an impaired ability to escape.	420 ppm*	150 ppm	83 ppm	33 ppm	27 ppm
Lethal Life-threatening health effects or death	1700 ppm	600 ppm	330 ppm	150 ppm	130 ppm

*1 ppm = 1 part of gas per million parts air by volume

Table 4 – Acute exposure guideline levels showing health effects of carbon monoxide concentration levels and exposure duration. Adapted from National Research Council (US) Committee on Acute Exposure Guideline Levels (AEG)

Appendix G: Safety Barriers

Safety barriers are controls intended to add layers of protection to mitigate the creation of and exposure to hazards. There are preventive barriers which prevent potential sources from creating a hazard and responsive barriers which can prevent a hazard from causing a consequence.

Safety barriers for CO in residential gas furnaces:

Figure 3 shows safety barriers that have been identified as mitigating the risks associated with CO in residential gas furnaces. The preventative barriers are intended to prevent the creation of the hazard which would be the production of dangerous concentrations of CO. The responsive barriers are intended to prevent consequences from the hazard which would be exposure to the dangerous concentrations of CO.

Safety barriers related to furnace heat exchanger failure:

Once the heat exchangers have degraded enough to restrict the flue products causing incomplete combustion and the production of hazardous concentrations of CO in the flue gas, all of the preventative barriers have failed. It is then reliant on responsive barriers to prevent exposure to hazardous concentrations of CO. These barriers are not always in place and have varying degrees of effectiveness.

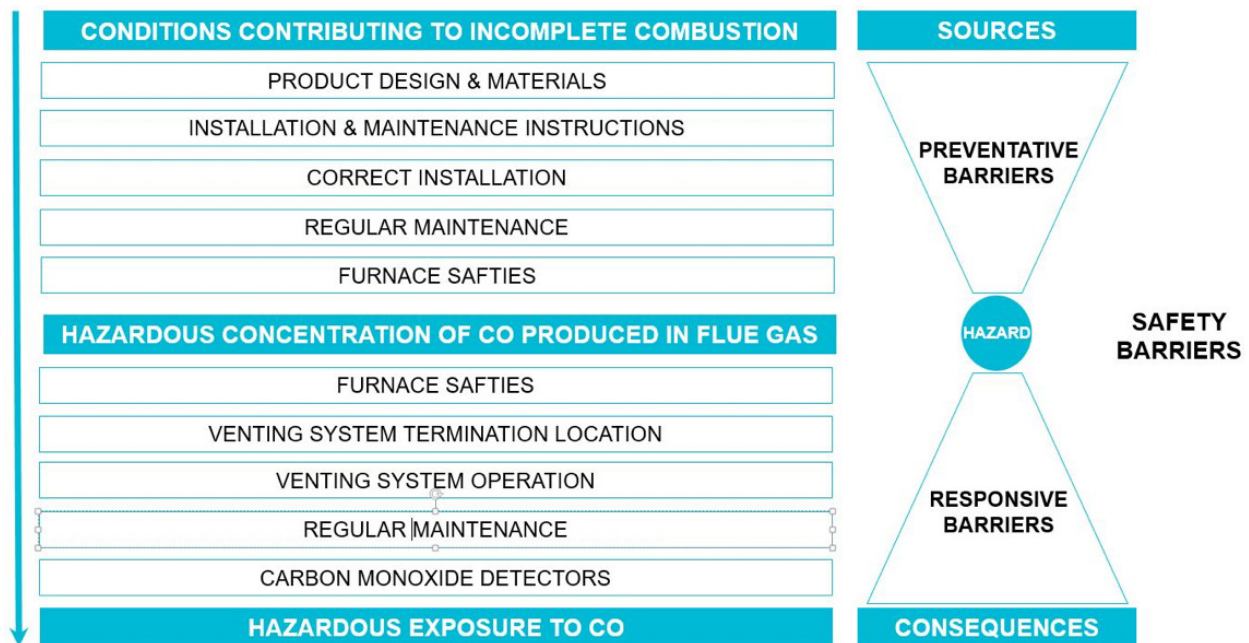

Figure 5: Actions to prevent failures and those to mitigate CO hazards following the failure.

Preventative barriers to avoid creating CO risks:

Design and materials of burners and flue gas passages

The manufacturers' design of furnace components must ensure continued safe operation of the furnace throughout its life span. Materials used by the manufacturer of the incident furnaces prematurely degraded producing hazardous levels of CO in the flue gas, which make this an in-effective safety barrier.

Installation and maintenance instructions

The installation and maintenance instructions dictate the correct methods of installation and the required maintenance actions and intervals. Evidence shows that even with correct installation and maintenance, furnace PLCHX's still degrade and produce hazardous concentrations of CO in the flue gas, which make this an in-effective safety barrier.

Although correct installation could delay the failure of the PLCHX, it was found as an ineffective barrier to the failure. Qualified contractors were found to have incorrectly installed furnaces, which make this an in-effective safety barrier.

Regular service and maintenance

Regular maintenance was shown to delay the failure of the PLCHX, it was not a proven barrier to the failure. Regular maintenance is reliant on the furnace owner understanding and following the maintenance requirements. Only a minority of residential gas furnaces were found to receive regular maintenance throughout the lifecycle of the appliance. When regular maintenance is performed, PLCHX's are not serviceable or accessible for inspection while installed in the furnace, which make this an in-effective safety barrier.

Furnace safeties

The furnace safeties in place to prevent hazardous levels of CO in the flue gas are the (1) air pressure switch and (2) flame rollout switch. Evidence has shown that the air pressure switch and flame rollout switch will not stop the operation of the furnace prior to the PLCHX degrading to the point they begin producing dangerous levels of CO in the flue gas which makes this an in-effective safety barrier.

Responsive barriers to prevent exposure to CO:

Furnace safeties

Evidence has shown that the air pressure switch will not stop the operation of the furnace in the event of a blocked PLCHX. The flame rollout switch is intended to stop operation of the furnace. This only occurs after the degradation to the PLCHX has progressed severely. The safety devices in place are not effective given that the furnace is able to remain in operation, possibly for years, while producing dangerous levels of CO in the flue gas.

Venting termination location

Properly located flue vent terminations can be an effective barrier to exposure to hazardous levels of CO in flue gas by directing flue gas away from occupied areas and allow air dilution to reduce the concentrations of CO to non-hazardous levels. Effectiveness of vent terminations as safety barriers are reliant on correct installation, clearances to building openings and mechanical air inlets. Horizontal vent terminations increase the risk of exposure to CO by reducing the amount of air dilution before potential exposure to the flue gases that could, in some cases, be recirculated into occupied spaces via building openings

Venting system installation

The installation of an effective venting system to remove the products of combustion safely to the outdoors can be an effective safety barrier to exposure to hazardous levels of CO. Effective venting is reliant on correct materials, design and installation practices, the lack of which can greatly increase the risk of CO exposure.

Regular service and maintenance

Regular service and maintenance can be an effective barrier to exposure to hazardous levels of CO by identifying incomplete combustion, degradation of the equipment or other causes of hazardous CO. Regular maintenance is reliant on the equipment owner knowing and following the maintenance requirements. Installation contractors have identified that only a minority of residential gas furnaces receive regular maintenance throughout the lifecycle of the appliance. Regular maintenance does not typically include flue gas analysis or CO detection. These factors reduce the effectiveness of this safety barrier.

CO detectors

CO detectors should be the last line of defense as a safety barrier and will activate only after other barriers have failed and high CO levels have entered the home. CO detectors as an effective barrier are reliant on being installed correctly in the space, having power or backup power to operate, and effectively alerting when hazardous levels of CO are present.

Safety barriers review:

As the secondary heat exchangers in the furnaces begins to fail, the equipment begins producing high levels of CO in the flue gas. The equipment continues to operate until the problem is identified either through (a) routine maintenance, (b) operating problems, or (c) Automated safety device shuts the furnace down.

It's estimated that the furnaces may operate for more than 5 years while producing hazardous levels of CO. During this time hazardous levels of CO are produced in the flue gas. The risk of exposure relies on the responsive barriers to ensure safety. As discussed earlier in this report, these safety barriers have not been to be effective in many cases.

In one incident, owners chose to continue operation of the furnace after it was shut down by a qualified contractor with a recommendation that it not be used. The physical safety switches on the equipment were then intentionally bypassed to allow for continued operation. The continued operation of an unsafe furnace elevated the exposure risk to toxic CO the entire time it continued to operate and relied on responsive safety barriers to not fail.

All the preventative safety barriers provided on the PLCHX furnaces were found to be ineffective and failed to prevent dangerous concentrations of CO in the flue gas

The responsive barriers available to avoid exposure to the CO hazard were found to be ineffective.

Appendix H: Technical Safety BC Jurisdiction and Role

Technical Safety BC administers the Safety Standards Act (“Act”) on behalf of the Province of British Columbia. The Act and associated Regulations apply to the following products, operations and work associated with these products:

- (i) amusement devices
- (ii) passenger ropeways
- (iii) boilers and boiler systems
- (iv) electrical equipment
- (v) elevating devices and passenger conveyors
- (vi) gas systems and equipment**
- (vii) pressure vessels
- (viii) pressure piping
- (ix) refrigeration systems and equipment; and
- (x) any other regulated product specified in the regulations.

The Act and Gas Safety Regulation (“Regulation”) applies in respect of gas systems and equipment including appliances in BC within the identified scope of the Act and Regulation. The gas systems, associated work and management of the gas equipment are subject to the Act and Regulation. Some municipalities administer portions of the Safety Standards Act. See www.technicalafetybc.ca for details. Incidents involving products or work subject to the Act are required to be reported in accordance with Section 36 of the Act. Technical Safety BC investigates these incidents in accordance with Section 37 of the Act and may appoint persons to assist with an investigation. The role of Technical Safety BC with respect to the investigation of incidents is to understand relationships between incidents, equipment and work that are subject to the Act. It is our aim to learn from these investigations what happened to inform efforts to prevent the recurrence of similar incidents. Often, these investigations are conducted in cooperation with other agencies including fire departments, WorkSafeBC, law enforcement officials, and the Coroners Service. This investigation report is issued by a Provincial Safety Manager and published in accordance with the Act. This report does not address issues of enforcement action taken under the Act. Any regulatory enforcement or compliance activities arising from this incident will be documented separately.

Appendix I: 90% Multi-Poise Condensing Furnaces Heat Exchanger and Sooting

View [here](#).

Appendix J: Technical Safety BC Investigation Incident #1 (II-982535-2020)

View [here](#).

Appendix K: Technical Safety BC Investigation Incident #2 (II-999966-2020)

View [here](#).

Appendix L: Technical Safety BC Investigation Incident #3 (II-1020945-2020)

View [here](#).

Appendix M: Technical Safety BC Investigation Incident #4 (II-997950-2020)

View [here](#).

Appendix N: Technical Safety BC Investigation Incident #5 (II-968311-2020)

View [here](#).

Appendix O: Acuren Report – Tube Failure Evaluations from Carrier Furnace Models

View [here](#).

Appendix P: Associated Engineering – Furnace Failure Investigations

View [here](#).

Visit [technical-safetybc.com](https://www.technical-safetybc.com)